

Mobile Equipment Maintenance **Solutions**



Bend-tech.
ENGINEERED TO DRIVE EFFICIENCY

Index

04

**ABOUT
BEND-TECH**

06 - 09

BUCKET REPAIR
Platforms and Stands

11 - 12

CATERPILLAR
D10 - D11

13

CATERPILLAR
16M Grader

14

CATERPILLAR
777 Haul Truck

15

CATERPILLAR
789 Truck

16 - 22

CATERPILLAR
793F Truck

23

CATERPILLAR
854K and 980 Stands

24 - 27

CATERPILLAR
994H Platforms

28

CATERPILLAR
996

29

CATERPILLAR
4400 Platforms

31

HITACHI
EX2500 Platform
and Tooling

32

HITACHI
EX3600 Tooling

33 - 35

HITACHI

EX5500 / 5600 Platforms
and Tooling

36

HITACHI

5000EH Platform

38

KOMATSU

730E Platforms
and Tooling

39 - 43

KOMATSU

830E Platforms,
Tooling and Stands

45

KOMATSU

930E Platforms

45 - 49

KOMATSU

WA1200 Platforms,
Tooling and Stands

51 - 54

LeTOURNEAU

L2350 Platforms

55

VOLVO

L120 Platforms

56

**UNDERGROUND
MACHINES**

LH621 Platforms

57

**UNDERGROUND
MACHINES**

CATERPILLAR AD30,
AD45B and AD55B

58

**UNDERGROUND
MACHINES**

CATERPILLAR 2900

59 - 60

**MAINTENANCE
PARTS**

61 - 62

**SUPPORT
STANDS**





ABOUT BEND-TECH

We deliver sustained value by providing cutting edge solutions through collaboration and innovation. For more than 30 years we have delivered intelligent design and custom-certified products and services to the Mining, and Mobile Equipment sectors across Australia and around the world.

We have achieved this through a deep understanding of our customers and their requirements as well as innovative and industry leading design, engineering and construction. Our platforms, stands, tooling, components and lifting and handling equipment is designed to make maintenance on your mobile equipment safe, efficient and easy.

“ **Making maintenance on-site safe, efficient and easy** ”

Bucket Repair Platforms



Face Shovel Bucket Repair Platform

Construction: Heavy duty aluminium

Forklift Slots: ✓

Our High Face Shovel Bucket Repair platform is used for the refurbishment and repair of buckets, and enables 3

sided access to large mining excavator and face shovel buckets in 180 to 400 tonne machine capacity range.

WLL: 250kg

Height: 1300mm



Part No. 5401529

Bucket Repair and Inspection Platform

Construction: Heavy duty steel

Forklift Slots: ✓

Our Bucket Repair and Inspection Platform provides safe access and inspection for large mining excavator and face shovel buckets.

Features

- Non-slip stairway and work area
- 7 step pathway
- Manufactured from Heavy duty steel
- Closing bar gate
- Forklift slots for ease of transport
- Safety handrails

WLL: 500kg

Height: 1500mm



Part No. 5401111

Bucket Repair Platforms



Part No. 5401522

Face Shovel Bucket Repair Platform

Construction: Heavy duty aluminium

Forklift Slots: 

Our High Face Shovel Bucket Repair platform is used for the refurbishment and repair of buckets, and enables 3 sided access to large mining excavator and face shovel buckets in 180 to 400 tonne machine capacity range.

WLL: 250kg
Height: 2300mm

Features

- Non-slip stairway and work area
- Walking pathway
- Self-closing gate
- Safety handrails
- Platforms are provided in 3 stage modular form to enable ease of transport, storage and installation.

“ Platforms can be customised to meet your specific needs and are engineered and certified to Australian Standards. ”

Bucket Stands



Bend-tech's heavy duty Bucket Support Stands can be used as single or pairs for loads up to 200 tonne. Our Bucket Support Stands also include forklift lifting slots for ease of transport.

Construction: Heavy duty steel

Forklift Slots:

Finish: Y14 Yellow

- Can be painted in accordance with the owner's specification



Part No. 5000000

200T - 300mm (h)

Construction: Heavy duty steel

Forklift Slots:

WLL: 200 Tonne

Height: 300mm



Part No. 5000001

200T - 600mm (h)

Construction: Heavy duty steel

Forklift Slots:

WLL: 200 Tonne

Height: 600mm



Part No. 5000002

200T - 900mm (h)

Construction: Heavy duty steel

Forklift Slots:

WLL: 200 Tonne

Height: 900mm

LeTOURNEAU L1850 Bucket Stand



Komatsu L1850 Bucket Stand

Construction: Heavy duty steel

Forklift Slots: 

- Fitted with lifting lugs
- Fitted with forklift slots for easy mobility

WLL: 100 Tonne

Height: 700mm



Part No. 5502242



CATERPILLAR

Product Range

Caterpillar D10 - D11 Platforms and Stand



Part No. 5501608

CAT D10 Engine Access Safety Platform

Construction: Heavy duty aluminium

Forklift Slots:

- Non-slip grating
- Overhanging platform
- Fitted with jacking stands

WLL: 250kg

Height: 2010mm



Part No. 5501587

CAT D11 Draft Arm Safety Stand 45 T

Construction: Heavy duty aluminium

Forklift Slots:

- Adjustable spring loaded
- Heavy duty wheels - spring loaded

WLL: 45 Tonne

Height: 1040mm

Caterpillar D10 - D11 Platforms



Part No. 5501737

CAT D10-D11 Engine Bay Platform

Construction: Heavy duty aluminium

Forklift Slots:

- Non-slip stairway and work area
- Handrails fully removable
- Jacking stands

- LH and RH configurations (Sold as a set)
- Detachable handrail with swinging gate section for protection when in the engine bay

WLL: 250kg

Height: 1850mm

CAT D10 Engine Access Platform

Construction: Heavy duty aluminium

Forklift Slots:

- Handrails fully removable
- Non-slip stairway and work area
- Self-closing gate
- Available in LH and RH configurations

WLL: 250kg

Height: 2010mm



Part No. 5501643



Caterpillar 16M Grader Platforms

CAT 16M Grader Access Platform

Construction: Heavy duty aluminium

Forklift Slots:

- Non-slip stairway and work area
- Self-closing gate
- Safety handrails

WLL: 250kg

Height: 1810mm



Part No. 5401519

CAT 16M Grader Cabin Access Platform

Construction: Heavy duty aluminium

Forklift Slots:

- Jacking stands fitted on the outriggers
- Non-slip stairway and work area
- Self-closing gate
- Safety handrails
- Overhang and counterweight for easy access

WLL: 250kg

Height: 1800mm



Part No. 5401590

Caterpillar 777 Haul Truck Platforms



CAT 777F Water Cart Access Platform

Construction: Heavy duty aluminium

Forklift Slots:

- Non-slip stairway and work area
- Self-levelling jacks
- Self-closing gate
- Safety handrails

WLL: 250kg

Height: 2230mm



Part No. 5501050

CAT 777-789F Air Filter Access

Construction: Heavy duty aluminium

Forklift Slots:

- Non-slip stairway and work area
- Safety handrails
- Self-levelling jacks and self closing gate

WLL: 250kg

Height: 2400mm



Part No. 5501024

Caterpillar 789 Truck Platforms and Tooling



CAT 777-789F Air Filter Access

Construction: Heavy duty aluminium

Forklift Slots:

- Non-slip stairway and work area
- Self-levelling jacks
- Self-closing gate
- Safety handrails

WLL: 250kg

Height: 2400mm



789 Hoist Cylinder Bearing Installer

Construction: Heavy duty steel

Forklift Slots:

Finish: Y14 Yellow

- Stainless steel certification plate
- For the easy and convenient installation of bearings

WLL: N/A

Height: N/A

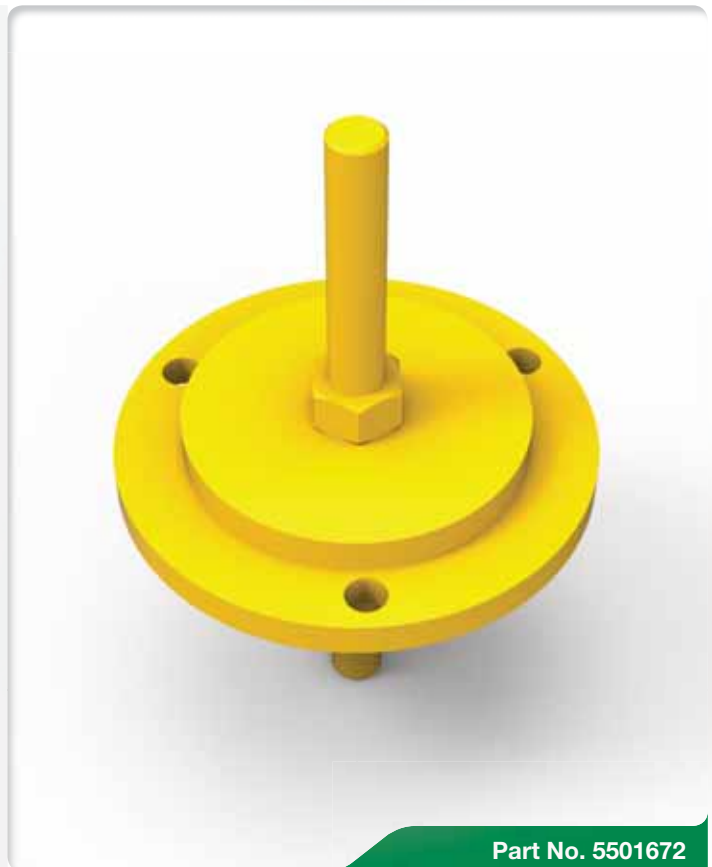

Caterpillar 793F Truck Stands



Part No. 5401525

CAT 793D Engine Support and Transport Stand

- Construction:** Heavy duty steel
Finish: Painted Y14 Golden Yellow
Forklift Slots:
 - Lifting eyes for ease of transport

WLL: 11 Tonne **Height:** 650mm



Part No. 5413106

CAT 793 Wheel Hub Support Frame

- Construction:** Heavy duty steel
Finish: Painted Y14 Golden Yellow
Forklift Slots:
 - Lifting eyes for ease of transport
 - Rollers to allow frame movement during maintenance

WLL: 7.8 Tonne **Height:** N/A

Caterpillar 793F Truck Platforms



CAT 793F Rear Struts Platform

Construction: Heavy duty aluminium

Forklift Slots:

- Large industrial castors and levelling jacks
- Non-slip stairway and work area
- Self-closing gate
- Safety handrails

WLL: 150kg

Height: 2100mm



Part No. 5501029

CAT 793F Upper Radiator Access

Construction: Heavy duty aluminium

Forklift Slots:

- Non-slip stairway and work area
- Large industrial castors and levelling jacks
- Non-slip stairway and work area
- Self-closing gate
- Safety handrails

WLL: 250kg

Height: 4000mm



Part No. 5415108

Caterpillar 793F Truck Platforms



CAT 793F Air Cleaner Platform

Construction: Heavy duty aluminium

Forklift Slots: ✓

- Jacking stands for stability
- Safety handrails (mandrel bent)
- Overhang self-closing gate for safety

WLL: 250kg

Height: 2800mm



Part No. 5501491

CAT 793F Lower Radiator Access Platform

Construction: Heavy duty aluminium

Forklift Slots: ✓

- Non-slip stairway and work area
- Large industrial castors and levelling jacks
- Self-closing gate and Safety handrails

WLL: 250kg

Height: 1800mm



Part No. 5414126



Caterpillar 793F Truck Platforms

CAT 793F Access Chassis Rail Platform

Construction: Heavy duty aluminium

Forklift Slots:

- Safety handrails
- Non-slip stairway and work area
- Self-closing gate, levelling jacks

WLL: 250kg

Height: 1700mm



Part No. 5501028

CAT 793F Wheel Rebuild Platform

Construction: Heavy duty aluminium

Forklift Slots:

- Removable handrails
- Work bench on both ends for tool storage
- Adjustable jacking stands for uneven ground

WLL: 350kg

Height: 530mm



Part No. 5501579

Caterpillar 793F Truck Platforms



Part No. 5501498

CAT 793F Strut And Line Boring Platform

Construction: Heavy duty aluminium

Forklift Slots:

- Removable handrails
- Overhang for extra access
- Easy access stairway

WLL: 250kg

Height: 2200mm



Part No. 5501500

CAT 793F Transmission Platform

Construction: Heavy duty aluminium

Forklift Slots:

- Removable handrails on platform and stairway
- Self-closing gate

WLL: 250kg

Height: 1700mm

CAT 793F Chassis Fuel Tank Access Platform

Construction: Heavy duty aluminium

Forklift Slots:

- Large overhang for extra length and access
- Self-closing gate at top of stairs
- Mesh on base

WLL: 250kg

Height: 3600mm



Part No. 5501495

Caterpillar 793F Truck Platforms



CAT 793F Engine Bay Access Platform

Construction: Heavy duty aluminium

Forklift Slots:

- 4 x Dropdown lifting lugs for safe lifting
- Removable handrails and fixed handrail on the end
- Self-closing gate

WLL: 450kg

Height: 1280mm



Part No. 5501480



Part No. 5501496

CAT 793F Drivers Side Access Platform

Construction: Heavy duty aluminium

Forklift Slots:

- Outriggers with stability jacks
- Self-closing gate and boom
- Heavy duty castor wheels

WLL: 250kg

Height: 4200mm



Part No. 5501483

CAT 793F Tray Pin Removal Platform

Construction: Heavy duty aluminium

Forklift Slots:

- Stability jacks
- Self-closing gate and boom
- Heavy duty castor wheels

WLL: 250kg

Height: 5250mm

Caterpillar 793F Truck Ladder



CAT 793F Truck Tray Access Ladder

Construction: Steel

Finish: CAT yellow

Forklift Slots:

- Access ladder positioned in the centre of the chassis
- Folding handrail for fall protection

WLL: 150kg

Height: 900mm



Part No. 5501941

Caterpillar 793F Truck Tooling



Part No. 5501058

CAT 793F Steering Arm Lifting and Flange Removal Tool

Construction: Heavy duty steel

Finish: Painted Y14 Golden Yellow

Forklift Slots:

WLL: 300kg

Height: N/A



Part No. 5512014

CAT 793 Rock Ejector Installation Tool

Construction: Heavy duty steel

Finish: Painted Y14 Golden Yellow

Forklift Slots:

WLL: 150kg

Height: N/A



Caterpillar 854K Stand

845K Wheel Dozer Draft Arm Stand

Construction: Heavy duty steel
Finish: Painted Y14 Golden Yellow

Forklift Slots:

- Swivel top stand with pin
- Folding handrail for fall protection

WLL: 50 Tonne

Height: 1100mm



Part No. 5501549

Caterpillar 980 Platforms



CAT 980M Safety Access Platform Set

Construction: Heavy duty aluminium

Forklift Slots:

- Non-slip stairway and work area
- Self-levelling jacks
- Self-closing gate
- Safety handrails

WLL: 250kg

Height: 1120mm



Part No. 5501549

Caterpillar 994H Platforms



Part No. 5501492

CAT 994H LH – RH Artic Short Platform

Construction: Heavy duty aluminium

Forklift Slots:

- Jacking stands for stability
- Self-closing gate

WLL: 250kg

Height: 900mm



Part No. 5501973

CAT 994 Access Stairs

Construction: Heavy duty steel

Finish: Painted Y14 Golden Yellow

Forklift Slots:

- Alternative option to OEM build
- Painted to site specific colour

WLL: 150kg

Height: 2300mm

Caterpillar 994H Platforms



CAT 994H Artic High Access Platform

Construction: Heavy duty aluminium

Forklift Slots:

- Outriggers with levelling jacks
- Boom rail on front
- Self-closing gate

WLL: 250kg

Height: 2840mm



Part No. 5501486



Part No. 5501919

CAT 994H Front Tilt Access Platform

Construction: Heavy duty aluminium

Forklift Slots:

- Steel plates weld to bucket
- Platform bolts onto welded plates
- Handrails Y14 safety yellow

WLL: 600kg

Height: 1280mm



Part No. 5501862

CAT 994H Emergency Side Access and Work Platform

Construction: Heavy duty aluminium

Forklift Slots:

- Removable handrails and floor section
- Self-closing gate

WLL: 400kg

Height: 2100mm

Caterpillar 994H Platforms



Part No. 5501487

994 Access Platform

Construction: Heavy duty aluminium

Forklift Slots:

- LH and RH side work platforms with additional middle platform

- Self-closing gate
- Safety handrails

WLL: 250kg

Height: 2850mm

CAT 994 LH – RH Artic Short Platform

Construction: Heavy duty aluminium

Forklift Slots:

- Platforms bolt together for transport
- Removable handrails for ease of access
- Compliant access platform kit for the left and right-hand side
- Self-closing gate

WLL: 250kg

Height: 3350mm



Part No. 5501499



Caterpillar 994H Platforms

CAT 2900 Platform

Construction: Heavy duty aluminium

Forklift Slots:

- Adjustable handrails at front
- Extended overhang for extra access
- Self-closing gate

WLL: 600kg

Height: 2860mm



Part No. 5501865

Caterpillar 994H Tooling

CAT 994H Transmission Holder

Construction: Heavy duty steel

Finish: Painted Y14 Golden Yellow

Forklift Slots:

- Designed specifically for the CAT 994H

WLL: 1.5 Tonne

Height: N/A

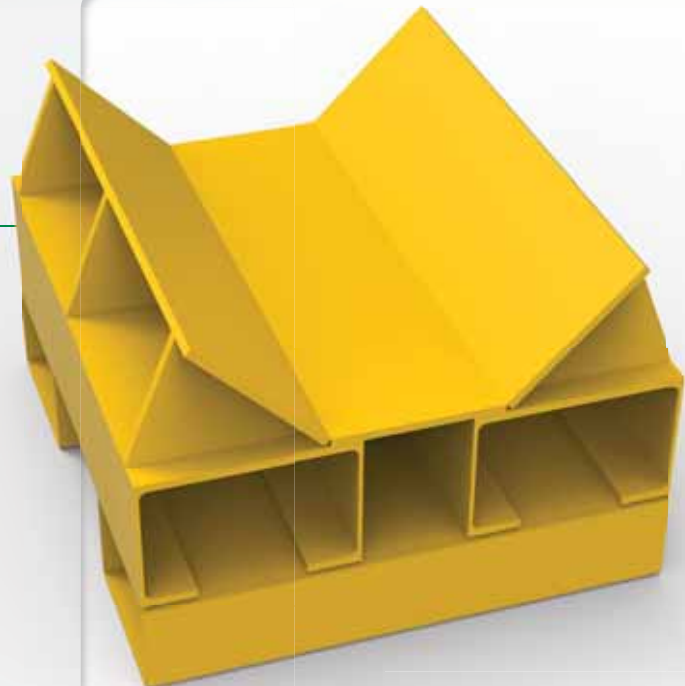

Part No. 5501502

Caterpillar 996 Platforms



CAT 996 Electrical Access Platform

Construction: Heavy duty aluminium

Forklift Slots:

- Small access platform
- Self-closing gate at the top of the stairs
- Fixed wheels at rear

WLL: 150kg

Height: 1000mm



Part No. 5501444

Caterpillar 4400 Platforms



CAT 4400 Front Access Platform

Construction: Heavy duty aluminium

Forklift Slots: 

- Large overhang for access
- Self-closing gate at the top of the stairs
- Safety handrails

WLL: 250kg

Height: 2180mm



Part No. 5501497



HITACHI

Product Range



Hitachi **EX2500** Platforms and Tooling

HITACHI EX2500 Platform Extension

- Construction:** Heavy duty steel
Finish: Painted Y14 Golden Yellow
Forklift Slots:
- Base plates lock into grate below

WLL: 250kg
Height: 2350mm



Part No. 5501633

Hitachi EX2500 Bash Plate

- Construction:** Heavy duty steel
Finish: Painted to site or machine specific colours
Forklift Slots:
- Modular design

WLL: N/A
Height: N/A



Part No. 5500152

Hitachi EX3600 Tooling



Hitachi EX5500/EX3600 Load Roller Cradle

Construction: Heavy duty steel
Finish: Y14 Golden Yellow
Forklift Slots:

WLL: 1200kg
Height: N/A

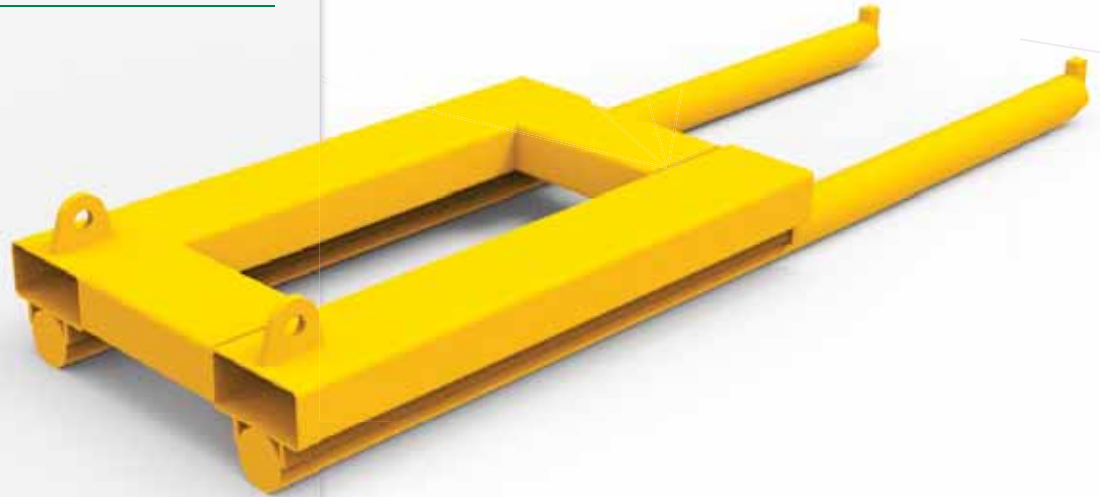

Part No. 5400171

EX3600 Load Roller Stand Placement Frame

Construction: Heavy duty steel
Finish: Y14 Golden Yellow
Forklift Slots:

- Radial lifter guides gusset and support plate

WLL: 200kg
Height: N/A



Part No. 5501545

Hitachi EX5500/5600 Platforms

HITACHI EX5500 / EX5600 Slew Bearing Platform – Changeout Kit

Construction: Heavy duty aluminium

Forklift Slots: 

- Complete with handrails
- Handrails gaps are half meshed for increased safety
- Handrails bolt on the fixed threaded blocks
- Removable platforms at front of platform

WLL: 250kg

Height: 2300mm



Part No. 5501259

HITACHI EX5500 Access Platform

Construction: Heavy duty aluminium

Forklift Slots: 

- Fitted with handrails that hook over tracks
- Platform sits at front of machine and handrails on edge of tracks

WLL: 250kg

Height: 2060mm



Part No. 5501245

Hitachi EX5500/5600 Platforms



HITACHI EX5600 Clam Cylinder Valve

Construction: Heavy duty aluminium

Forklift Slots:

- Fitted with Self-closing gate and safety handrails
- Non-slip stairway and work area
- Wheels for ease of mobility
- Certified and compliant with Australian Standards

WLL: 250kg

Height: 1800mm



Part No. 5501451

HITACHI EX5500 Boom Hose Platform

Construction: Heavy duty aluminium / steel

Forklift Slots:

- Eliminates the need for scaffold
- Permanent steel members welded to machine
- Interchangeable aluminium access planks

WLL: 250kg per plank

Height: 150mm

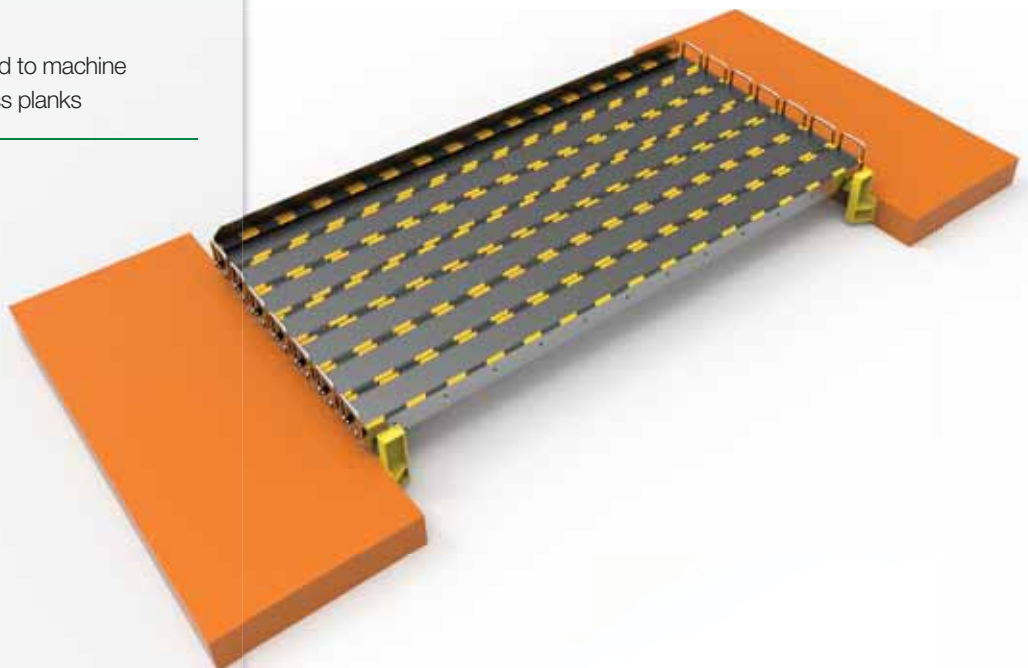

Part No. 5501432



Hitachi EX5500/5600 Tooling



Part No. 5400171

Hitachi EX5500/EX3600 Load Roller Cradle

Construction: Heavy duty steel
Finish: Painted Y14 Golden Yellow
Forklift Slots:

WLL: N/A
Height: N/A



Part No. 5501992

Hitachi EX5500 Arm Cylinder Transport Frame

Construction: Heavy duty steel
Finish: Hot dipped galvanised
Forklift Slots:

- Allows for easy, safe transport



Part No. 5501993

Hitachi EX5500 Boom Cylinder Transport Frame

Construction: Heavy duty steel
Finish: Hot dipped galvanised
Forklift Slots:

- Allows for easy, safe transport



Part No. 5501994

Hitachi EX5500 Bucket Cylinder Transport Frame

Construction: Heavy duty steel
Finish: Hot dipped galvanised
Forklift Slots:

- Allows for easy, safe transport

Hitachi 5000EH Platform



HITACHI 5000EH Engine Bay Access Platform

- Construction:** Heavy duty aluminium
- Forklift Slots:**
- Jacking Stands:**

WLL: 250kg
Height: 2830mm



Part No. 5501732





KOMATSU

Product Range

KOMATSU 730E Platform and Tooling



Komatsu 730E Engine Bay Platform

- Construction:** Heavy duty aluminium
Finish: Painted Y14 Golden Yellow
Forklift Slots:
- Supplied in pairs
 - Extended height handrails

WLL: 200kg
Height: 580mm



Part No. 5501231

Komatsu 730E / 830E Wheel Hub Support Frame

- Construction:** Heavy duty steel
Finish: Painted Y14 Golden Yellow
Forklift Slots:
- Lifting eyes for ease of transport
 - Tie down points for stability

WLL: 1500kg
Height: N/A

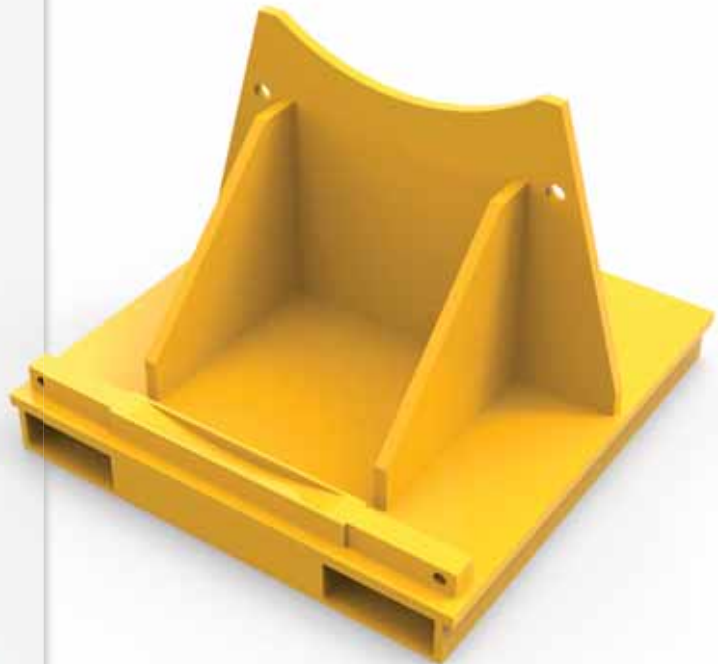

Part No. 5000105

KOMATSU 830E Platforms



KOMATSU 830E Air Filter Access Station Platform

Construction: Heavy Duty Alloy
/ Steel

Forklift Slots:

- Non-slip grating
- Solar lights are added to the platform for extra light at night

WLL: 350kg
Height: 2450mm



Part No. 5501548

KOMATSU 830E Platforms



KOMATSU 830E Over Fuel Tank Access Platform

Construction: Heavy duty aluminium

Forklift Slots:

- Out-swinging gates
- Non-slip platform
- Safety handrails

WLL: 350kg

Height: 3800mm



Part No. 5501514



Part No. 5001793

KOMATSU 830E Engine Bay Access Platform And Ladder

Construction: Heavy duty aluminium

Finish: Painted Y14 Golden Yellow

Forklift Slots:

- Extended height handrails
- Sliding access door and Fold-down ladder

WLL: 150kg

Height: 1040mm



Part No. 5501360

Komatsu 780E Engine Bay Platform

Construction: Heavy duty aluminium

Finish: Painted Y14 Golden Yellow

Forklift Slots:

- Supplied in pairs
- Extended height handrails

WLL: 150kg

Height: 580mm

KOMATSU 830E Platforms

KOMATSU 830E ACI Engine Modules Platform

Construction: Heavy duty aluminium

Forklift Slots: 

- Access for both sides of engine
- Non-slip platform and handrails

WLL: 200kg

Height: 750mm



Part No. 5501247

KOMATSU 830/930 Front Entry Access Platform Stairs

Construction: Heavy duty aluminium

Forklift Slots: 

- Dual self-closing gates at the rear of the platform
- Non-slip platform and landings

WLL: 150kg

Height: 800mm



Part No. 5501721

KOMATSU 830E Platforms



Part No. 5002104

KOMATSU 830E Platform with Ladder RHS

Construction: Heavy duty
Aluminium Ladder / Steel Platform

Finish: Painted Y14 Golden Yellow

Forklift Slots:

- Locking gates for safety
- Can be modified for tyre and truck configurations

WLL: 200kg

Height: 580mm



Part No. 5002105

KOMATSU 830E Platform with Ladder LHS

Construction: Heavy duty
Aluminium Ladder / Steel Platform

Finish: Painted Y14 Golden Yellow

Forklift Slots:

- Locking gates for safety
- Can be modified for tyre and truck configurations

WLL: 200kg

Height: 580mm

KOMATSU 830E Tooling and Stands

KOMATSU 830E Lifting Jig

Construction: Heavy duty steel

Forklift Slots:

Finish: Painted Y14 Golden Yellow

- Straps fitted to hold steering accumulator in place
- Finished in Y14 Safety Yellow

WLL: 500kg

Height: N/A



Part No. 5501743

Komatsu 730E / 830E Wheel Hub Support Frame

Construction: Heavy duty steel

Forklift Slots:

Finish: Painted Y14 Golden Yellow

- Lifting eyes for ease of transport
- Tie down points for stability

WLL: 1500kg

Height: N/A

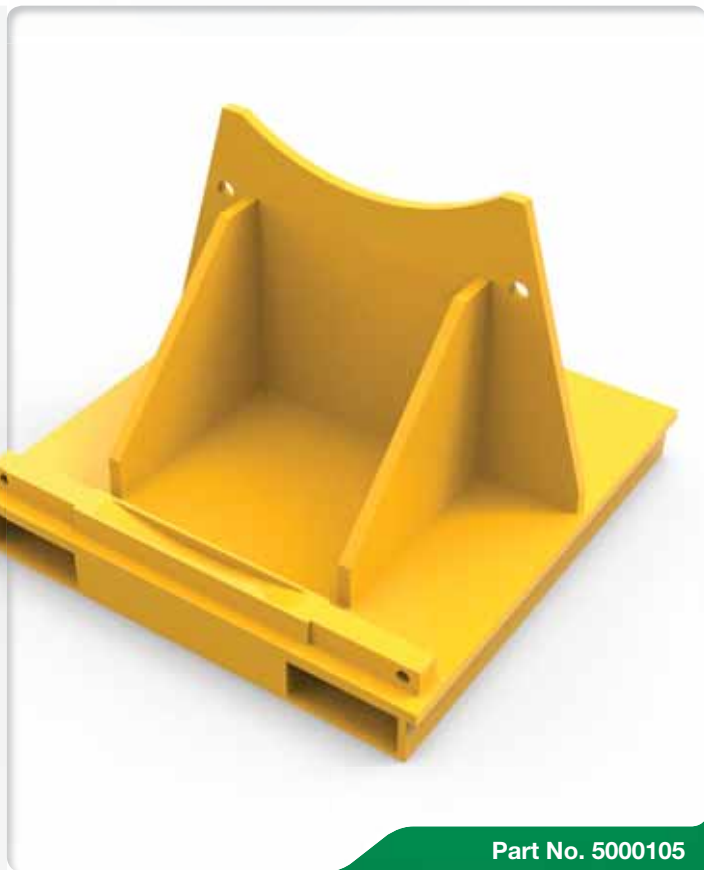

Part No. 5000105

KOMATSU 930E Platforms



KOMATSU 830/930 Front Entry Access Platform Stairs

Construction: Heavy duty aluminium

Forklift Slots:

- Dual self-closing gates at the rear of the platform
- Non-slip platform and landings

WLL: 600kg

Height: 800mm



Part No. 5501721

KOMATSU 930E Strut Platform

Construction: Heavy duty aluminium

Forklift Slots:

- Removable handrails on front for easy access
- Outriggers for extra stability

WLL: 250kg

Height: 2300mm



Part No. 5501773

KOMATSU WA1200 Platforms



Komatsu WA1200 Front Artic / Boom Hose Access

Construction: Heavy duty aluminium

Forklift Slots:

- Large industrial castors and levelling jacks
- Non-slip stairway and work area
- Self-closing gates
- Safety handrails

WLL: 250kg

Height: 1150mm



Part No. 5501039



KOMATSU WA1200 Platforms



KOMATSU WA1200 Artic Front Area Strut Platform

Construction: Heavy duty aluminium

Forklift Slots:

- LH and RH configurations
- Removable handrails on all sides for easy access
- Self-closing gate

WLL: 250kg

Height: 1900mm



Part No. 5501638

KOMATSU WA1200 Front Hatch Access Platform

Construction: Heavy duty aluminium

Forklift Slots:

- Flip down handrails
- Self-closing gate

WLL: 250kg

Height: 3000mm



Part No. 5501582



KOMATSU WA1200 Platforms

KOMATSU WA1200 Internal Transmission Area Access Platform

Construction: Heavy duty aluminium

Forklift Slots:

- Recessed lifting lugs in platform deck for crane access
- Narrow access

WLL: 150kg

Height: 2290mm



Part No. 5501628

KOMATSU WA1200 Front Hatch Access Platform

Construction: Heavy duty aluminium

Forklift Slots:

- Weld on steel base plates
- Handrails thread on to steel blocks welded to WA1200

WLL: 150kg

Height: 1400mm

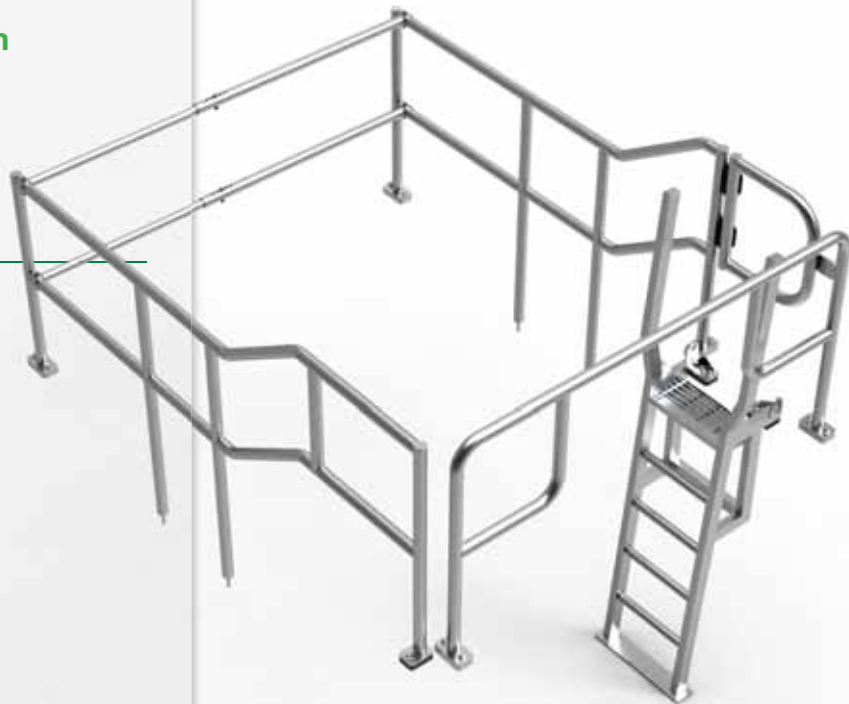

Part No. 5501654

KOMATSU WA1200 Stands



Komatsu WA 1200 Complete Stand Set

Construction: Heavy duty steel
Finish: Painted Y14 Golden Yellow
Forklift Slots:

- Includes 3 stands

SMALL STAND

WLL: 200T
Height: 840mm

MEDIUM STAND

WLL: 200T
Height: 1130mm

LARGE STAND

WLL: 200T
Height: 1400mm



Part No. 5501693

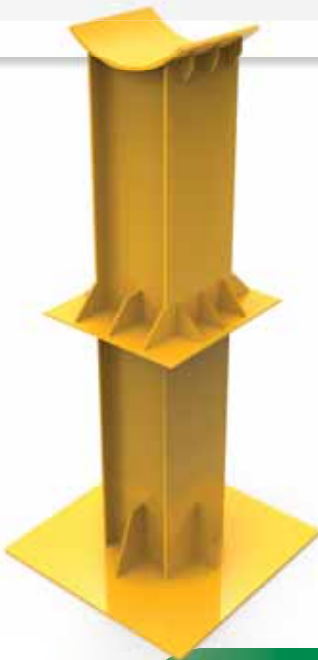

Part No. 5000013

Komatsu WA1200 Torque Tube Support Stand

Construction: Heavy duty steel
Finish: Painted Y14 Golden Yellow
Forklift Slots:

- Curved top

WLL: 80 Tonne **Height:** 3500 or 3700mm



Part No. 5501052

80 Tonne Boom Support Stand

Construction: Heavy duty steel
Finish: Painted Y14 Golden Yellow
Forklift Slots:

- Lifting eyes for ease of transport

WLL: 100 Tonne **Height:** 4500mm

KOMATSU WA1200 Tooling

WA1200 Bush Lifting Tool

Construction: Heavy duty steel

Finish: Painted Y14 Golden Yellow

Forklift Slots: 

- Rubber insertion
- Finished in Y14 safety yellow

WLL: 100kg

Height: N/A



“ Making maintenance
on-site safe, efficient
and easy ”



LeTOURNEAU

Product Range

LeTOURNEAU L2350 Platforms

L2350 Side Access Platform

Construction: Heavy duty aluminium

Forklift Slots: 

- LH and RH configuration
- Levelling jacks for uneven ground
- Removable handrails

WLL: 250kg

Height: 4350mm



Part No. 5501574

L2350 Artic Area Access Platform

Construction: Heavy duty aluminium

Forklift Slots: 

- Heavy duty castor wheels
- Outriggers with stability jacks
- Platform bolts together in a top and bottom section
- Self-closing gate at top of stairs and boom rail at rear

WLL: 250kg

Height: 3100mm



Part No. 5501580

LeTOURNEAU L2350 Platforms



L2350 RH Chassis Access Platform

Construction: Heavy duty aluminium

Forklift Slots:

- Slide-out handrail for extra protection
- Wide Stairway for easy access

WLL: 250kg

Height: 3550mm



Part No. 5501766

L2350 Air-con Condensor Access Platform

Construction: Heavy duty aluminium

Forklift Slots:

- Lifting lugs to crane into place
- Rubber on base plates for stability when on deck
- Self-closing doors

WLL: 150kg

Height: 550mm



Part No. 5501891



LeTOURNEAU L2350 Platforms

L2350 LH Chassis Access Platform

Construction: Heavy duty aluminium

Forklift Slots:

- LH and RH configuration
- Levelling jacks for uneven ground
- Removable handrails

WLL: 250kg

Height: 3550mm



Part No. 5501575

L2350 LH & RH Strut Removal Platform

Construction: Heavy duty aluminium

Forklift Slots:

- Suits left and right hand configurations
- Removable Handrails
- Removable step
- Self-closing doors

WLL: 150kg

Height: 1600mm



Part No. 5501735

LeTOURNEAU L2350 Platforms



L2350 RH Chassis Access Platform

Construction: Heavy duty aluminium

Forklift Slots:

- Fixed on the front section
- Handrails for safe access

WLL: 600kg

Height: N/A



Part No. 5501736



VOLVO L120 Platforms



L120F Volvo Access Platform

Construction: Heavy duty aluminium

Forklift Slots:

- Left and right-hand platforms for easy access on both sides of the loader
- Overhangs for easy access
- Easy to move around the workshop while the loader is serviced

WLL: 600kg

Height: 2050mm



Part No. 5501968

Underground SANDVIK LH621 Platform



SANDVIK LH621 Loader Front Access Platform

Construction: Heavy duty aluminium

Forklift Slots:

- Platforms allow easy access from the bucket right to the cab
- Left hand and Right hand are symmetrical
- Double height handrails at tyre points to prevent falls
- Flip up grating sections on deck

WLL: N/A

Height: N/A



Part No. 5501967



Underground Caterpillar **AD30**, **AD45B** and **AD55B** Platforms



Part No. 5501823

CAT AD30 Tray Access Platform

Construction: Heavy duty aluminium

Forklift Slots:

- Non-slip grating
- Handrails fully removable
- Self-closing gate

WLL: 600kg

Height: 2150mm



Part No. 5501806

CAT AD45B Rear Tray Access Platform

Construction: Heavy duty aluminium

Forklift Slots:

- Non-slip grating
- Handrails fully removable
- Self-closing gate

WLL: 600kg

Height: 2550mm



CAT AD55B Access Platform

Construction: Heavy duty aluminium

Forklift Slots:

- Non-slip stairway and work area
- Self-levelling jacks
- Self-closing gate
- Foldable handrail wings

WLL: 600kg

Height: 2200mm



Part No. 5501846

Underground Caterpillar **2900** Platforms



Part No. 5501730

CAT 2900 Bucket Reconditioning Platform

Construction: Heavy duty aluminium

Forklift Slots:

- 4 x sections bolt together to combine in one square shaped platform
- Removable handrails

WLL: 250kg

Height: 1700mm

CAT 2900 Platform

Construction: Heavy duty aluminium

Forklift Slots:

- Self-closing gate at the top of the stairs
- Safety handrails

WLL: 250kg

Height: 2050mm



Part No. 5501557

Maintenance Parts

Bearing Push Tool

Construction: Heavy duty steel

Finish: Painted Y14 Golden Yellow

Forklift Slots:

- Lifting eyes for ease of installation and transport
- Can be made to suit custom sizes.
- Tonnages are available on request

WLL: 25 Tonne

Height: N/A



Part No. 5414102

Grader Blade Forklift Attachment

Construction: Heavy duty steel

Finish: Painted Y14 Golden Yellow

Forklift Slots:

- Suited to Terex RH170 machines
- To be on forklift of approved weight.
- Storage compartment
- Painted safety yellow

WLL: 370kg

Height: N/A

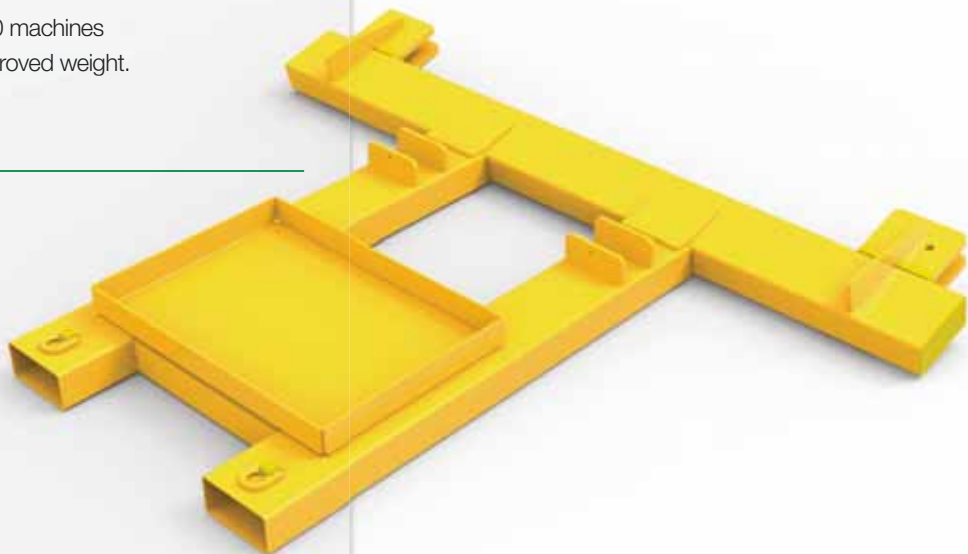

Part No. 5401575

Maintenance Parts



Komatsu Brake Caliper Tooling

Construction: Heavy duty steel

Finish: Painted Y14 Golden Yellow

Forklift Slots: 

- Made specifically to suit Komatsu machines
- Enables safe and efficient handling of brake calipers by positioning the caliper off work benches and providing full rotation.

WLL: 50kg

Height: N/A



Part No. 401552

Support Stands

30 Tonne Support Stand

Construction: Heavy duty steel

Finish: Painted Y14 Golden Yellow

Forklift Slots:

- Ensure the stand remains functional under high workloads
- Features a high wear top plate

WLL: 30 Tonne

Height: 655mm



Part No. 5501038

50 Tonne Support Stand

Construction: Heavy duty steel

Finish: Painted Y14 Golden Yellow

Forklift Slots:

- Ensure the stand remains functional under high workloads
- Features a high wear top plate

WLL: 50 Tonne

Height: 670mm



Part No. 5511038

Support Stands

60 Tonne SKS Drill Chassis Support Stand

- Construction:** Heavy duty steel
- Finish:** Painted Y14 Golden Yellow
- Forklift Slots:**
- Used for support of the SKS mining drill

WLL: 60 Tonne
Height: 1700mm



Part No. 500017

We offer a full consulting and engineering service

Projects and the associated challenges often require custom solutions, we take pride in our CDEC system. Consultation, Design, Engineering and Construction is our holistic approach to solution development making maintenance on-site safe, efficient and easy.

CDEC Process



Consultation We come to you and visit your site to get a hands-on feel for your project. The aim of our consultation is to listen to and understand your requirements. This approach allows us to develop and discuss with you on-site, possible solutions to your problem, and the benefits we can offer.



Design After the consultation we go back to our design team to begin the development of your custom solution. Our team produce designs in **CAD Design** complete with all drafting documentation ensuring an advanced manufacturing process. Our process allows and encourages you to be involved in the design stage and collaborate with our highly skilled team.

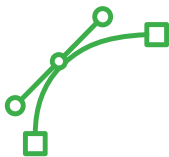

Engineering Once the design is approved we begin the development and engineering process. This ensures that the right material is used for your project to guarantee structural and functional integrity. We provide full certification that includes WLL, load ratings, integrity reports as well as certificate plates and identifications. We design and engineer all our solutions to ensure full compliance with Australian standards.



Construction Finally, once the project is ready and certified for construction we manufacture your solution. We test, machine, fabricate and surface treat as well as trial fit your custom project. We only manufacture high quality products that provide long lasting, safe and efficient solutions.





PERTH 08 9459 8600
SYDNEY 02 9764 6607
BRISBANE 07 3117 3780

KALGOORLIE 08 9021 8300
NEWMAN 08 9175 1164
MOUNT ISA 07 4743 6458

sales@bendtechgroup.com.au
www.bendtechgroup.com.au